

Noise Barriers

European Standards – CE Marking



Giovanni Brero

ENBF President www.enbf.org

« *pauca sed matura* »

C. F. Gauss



Let's call things with their name

Noise Reducing Device??

better:

Larmschutz

Barriera antirumore

Pantalla antiruido

Noise barriers

Ecran antibruit

Geluidsscherm

Ekrany Akustyczne

ENBF Effective Members

- **Asociación Nacional de Industriales de Pantallas y dispositivos Anti-ruido (ANIPAR), Spain + Portugal**
- **Association Professionnelle des Réalisateurs d'Ecrans Acoustiques (APREA), France**
- **Deutscher Verband für Lärmschutz an Verkehrswegen e.V. (DVLV), Germany**
- **Unione Nazionale delle Industrie delle Costruzioni Metalliche (UNICMI), Italy**

Associated Members

- **Bayer Sheet Europe, Belgium**
- **CIR Ambiente, Italy**
- **DECEUNINCK NV, Belgium**
- **EVONIK, Austria**
- **KOHLHAUER GmbH, Germany**
- **MICE SA, Belgium**
- **Van Campen Industries B.V, Netherlands**
- **Alfa Bond Kohlhauer Sp. z o. o. , Poland**
- **LS Lublow GmbH, Germany**
- **Akripol, Slovenia**



A PATH FOR EU LEGISLATION AND TECH STANDARDS

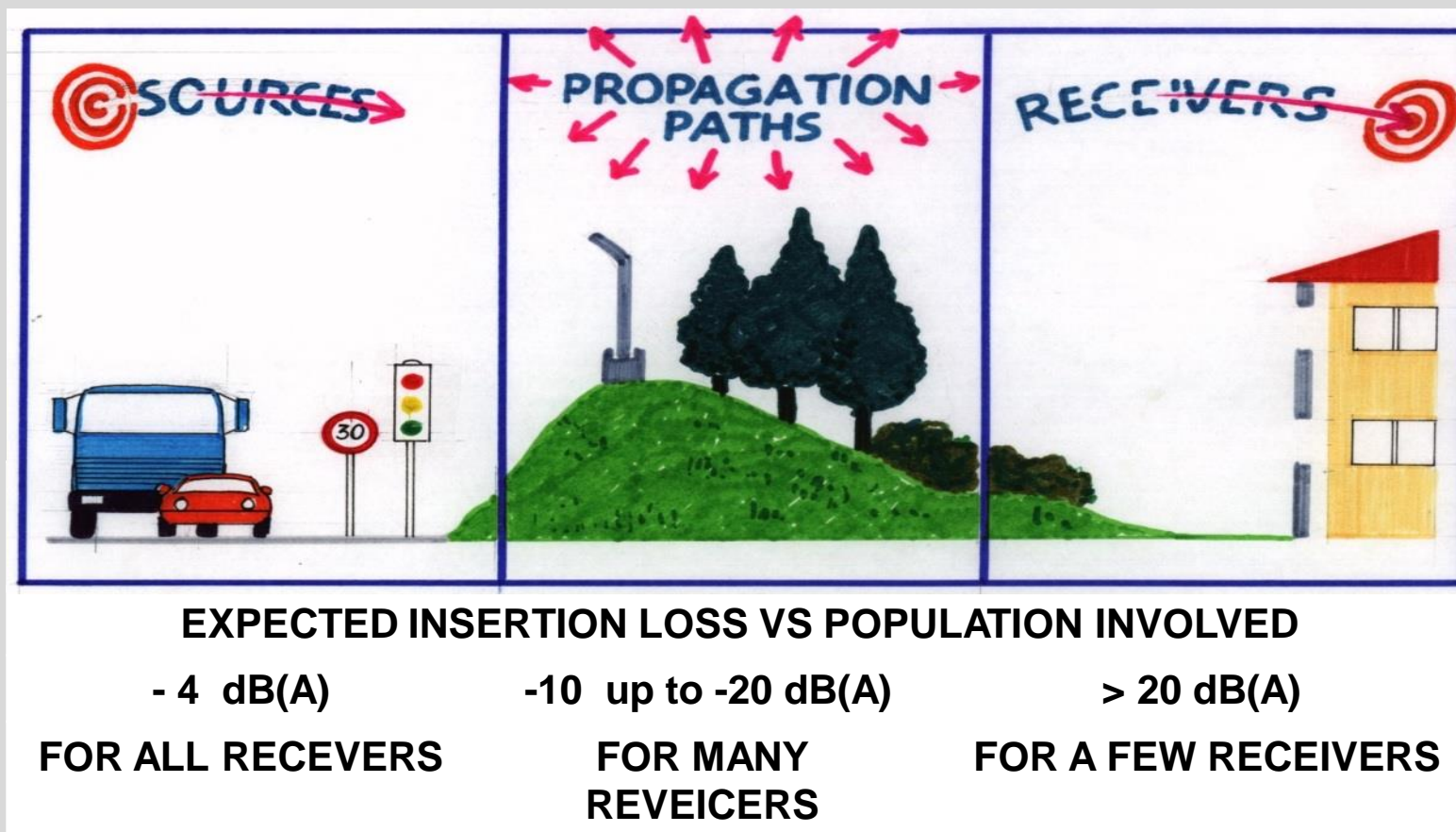

ENBF TASK N.1 - To provide informative support and cooperation to the bodies in charge of writing European legislation and European technical standards.

NEED FOR CORRECT RULES ON THE MARKET

CE MARKING AND PERFORMANCE TO BE EVALUATED ON THE NOISE BARRIER SYSTEM

ENBF TASK N.2 - To set up the basis for cooperation between industry, public administration and other relevant stakeholders

NEED OF CLEAR COMMUNICATION TO THE PUBLIC

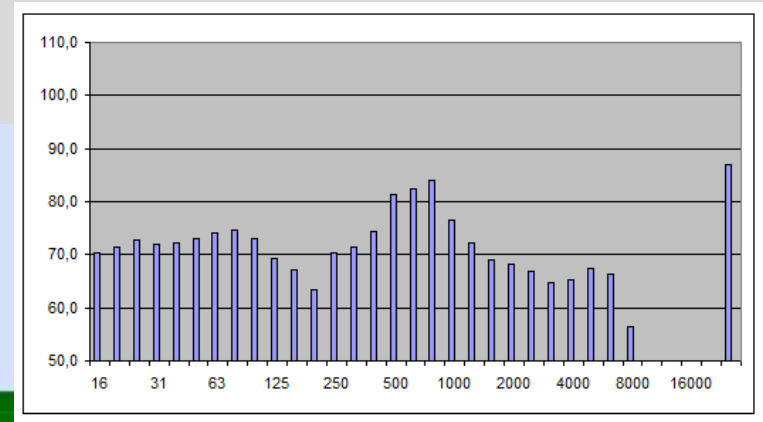
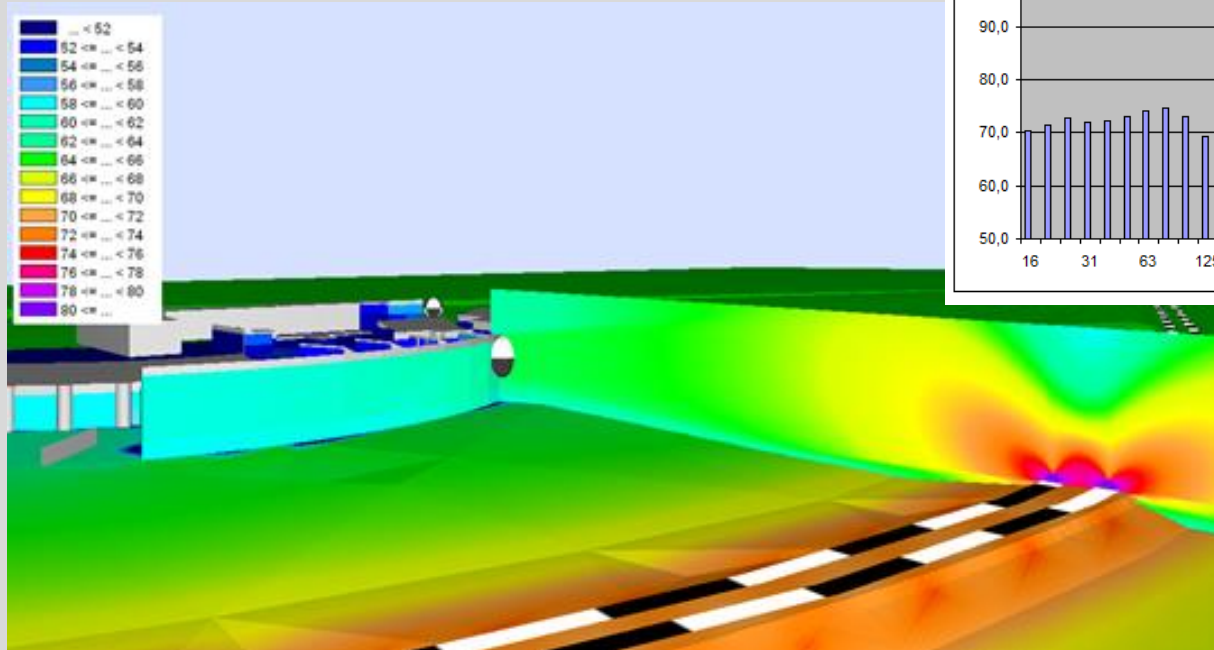

70 + 70 = 73 dB(A) ??

1. ENBF TASK N.3 - to develop communication tools in order to spread knowledge and expertise to a large audience.



NOISE BARRIERS ACROSS EU NEED OF MERGING EXPERIENCES

ENBF TASK N.4

**To exchange knowledge and expertise on
products and solutions among members
of the federation**

THE VARIETY OF THE MARKET MAY LEAD TO BARRIERS TO TRADE ?



Noise barriers are construction products under CPR (Construction Product Regulation n. 305/2011) that means:

hEN 14388:2005 is the only reference harmonised European standard written by CEN under a specific EU Commission Mandate

Manufacturers are asked to :

- Declare NOISE BARRIER performance of essential characteristics**
- Affix the CE marking >> to take responsibility for the conformity of the NOISE BARRIER with the declared performances**

DoP (Declaration of Performance)

Noise barrier (NOT a part of it) is the product to be incorporated into a road infrastructure and its performance has to be declared for the essential characteristics:

CPR
1- Mechanical resistance and stability
2- Safety in case of fire
3- Hygiene, health and the environment <i>throughout the life cycle + safety of workers</i>
4- Safety and accessibility in use
5- Protection against noise
6- Energy economy and heat retention Energy efficiency of construction work during construction and dismantling
7- Sustainable use of natural resources

CE marking for Noise Barriers to be installed alongside Road Infrastructures
ENBF – Guidelines & Recommendations (<http://www.enbf.org/outcomes.htm>)

DoP of the noise barrier system What is CE marking?

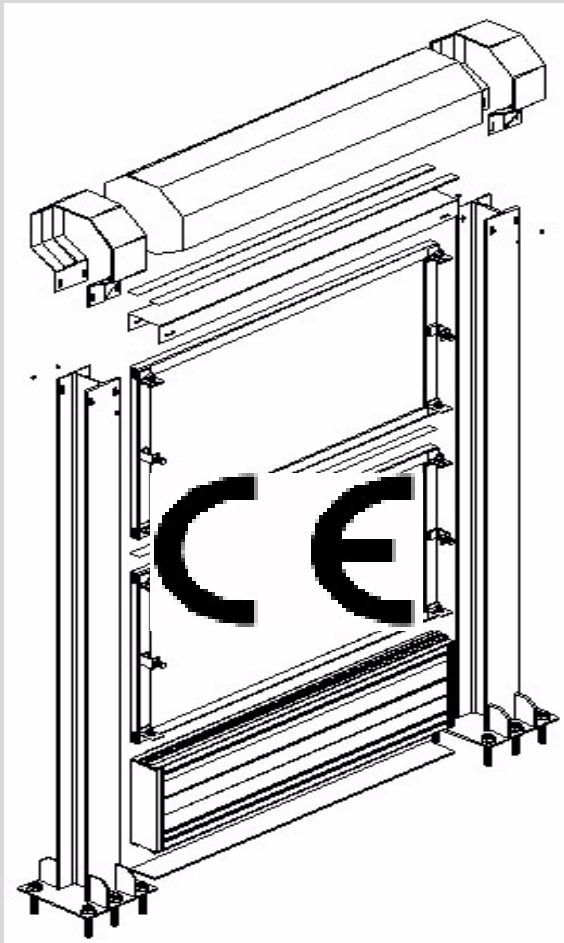

NOISE BARRIER SYSTEM is the ROAD EQUIPMENT requiring for CE marking

PERFORMANCE is to be assessed on the noise barrier system

It is NOT a mere collection of single components technical datasheets

Often may happen that:

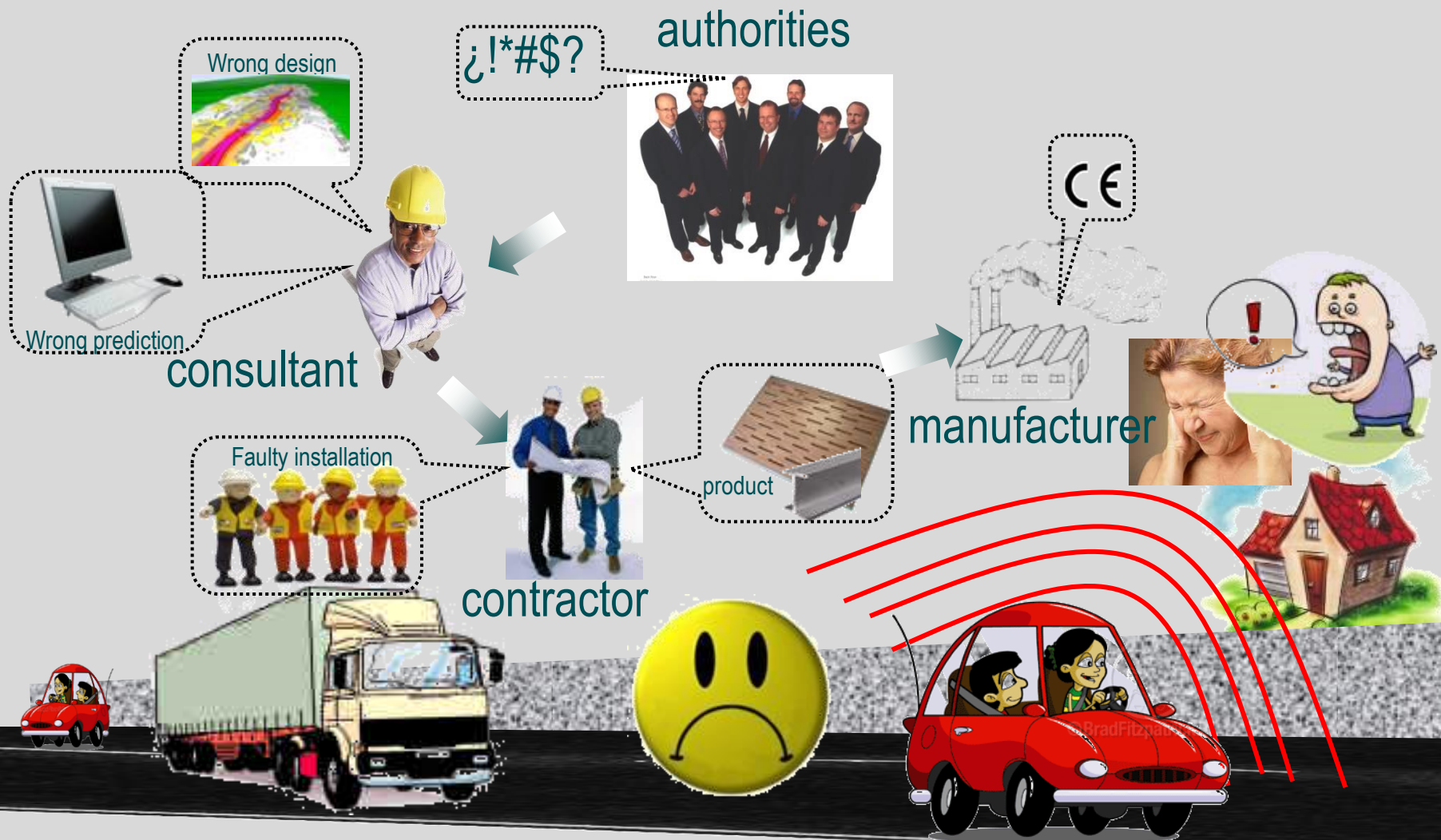

It should be like that:

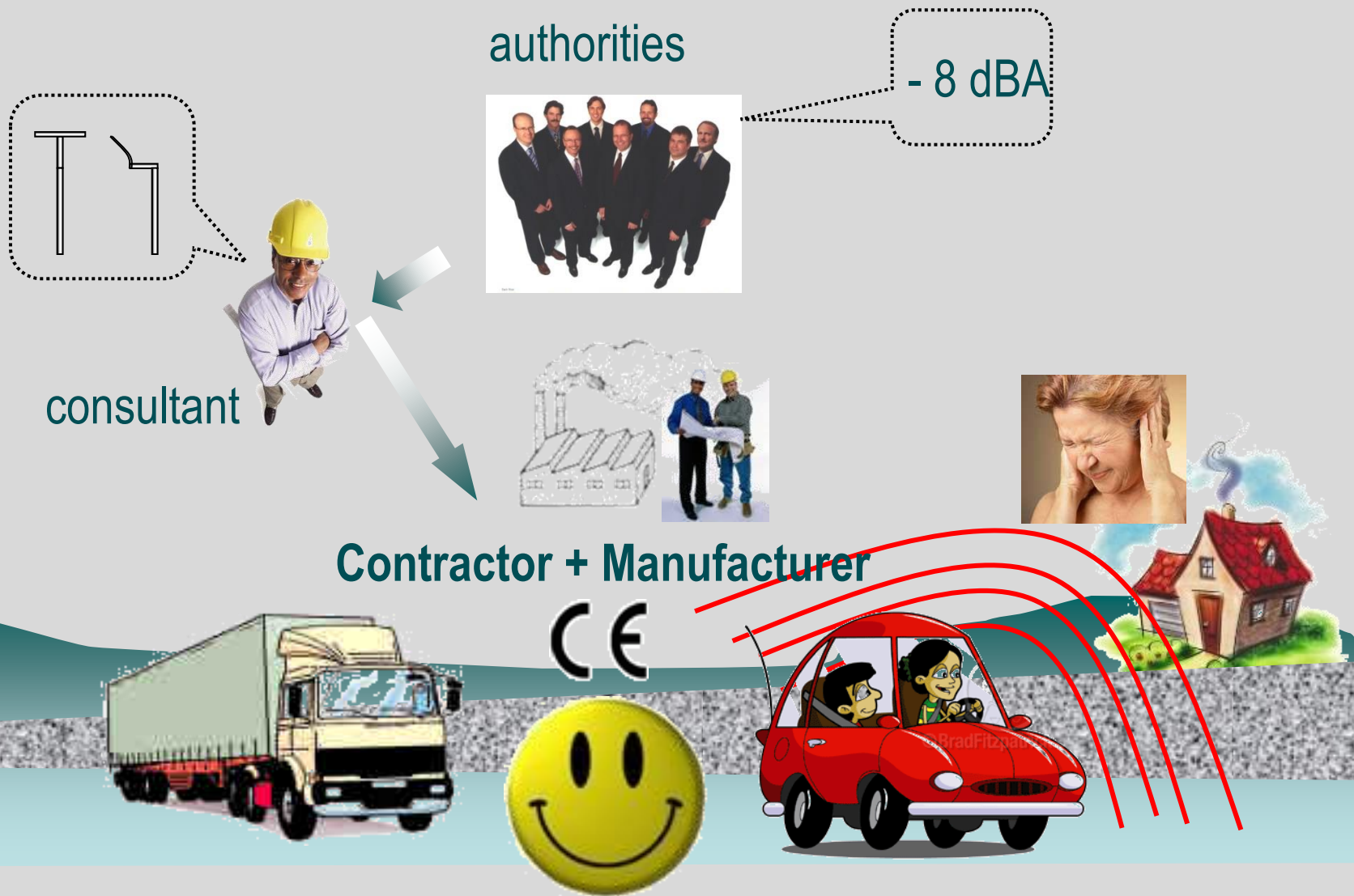

hEN does not fix product requirements unless threshold values are established within the standards by Mandate

Authorities or Member State are in charge of establishing requirements but shall not impede the use of construction products bearing the CE marking, when the declared performances correspond to the requirements for such use in that Member State

**Members State shall not introduce other regulations
(Directive 98/34/EC - notification of new regulations)**

Public Procurement must be open to competition (EU Directives on public procurement)

Use of hEN 14388 has to be made by all actors (regulators, engineers producers, contractors) in a “common European technical language”

CE marking >> DoP of the noise barrier system

Acoustic performance: insulation + absorption



Reverberant chamber method (EN 1793.1 and 2)

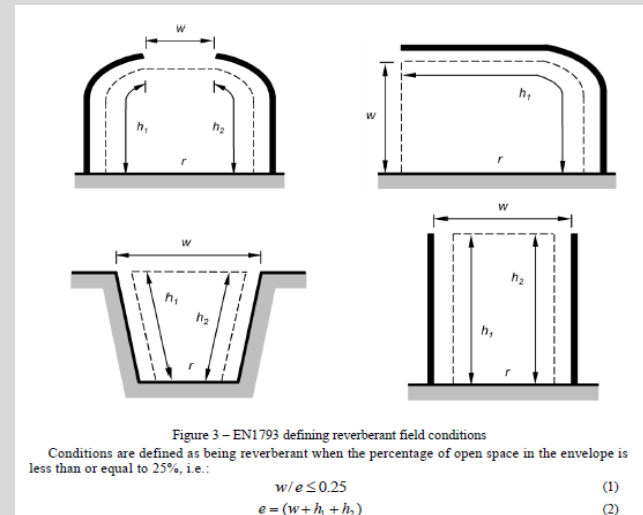

In situ method (CEN TS 1793.5 - EN 1793.6)

Evaluation to be performed on the noise barrier system

ACOUSTIC PERFORMANCE

Present State of the Art on Methods for CE marking

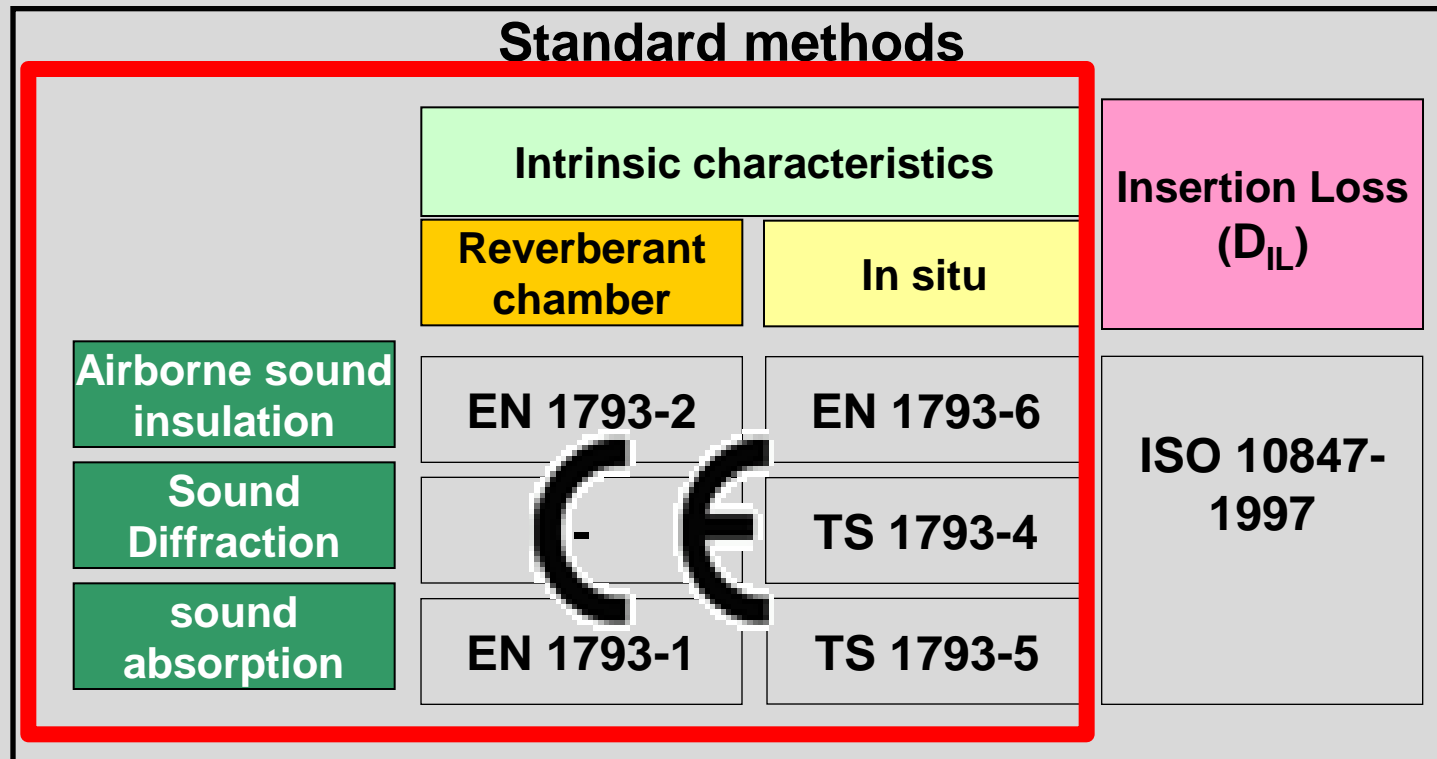

ACOUSTIC PERFORMANCE

Methods for Qualifying Noise Barrier Effectiveness

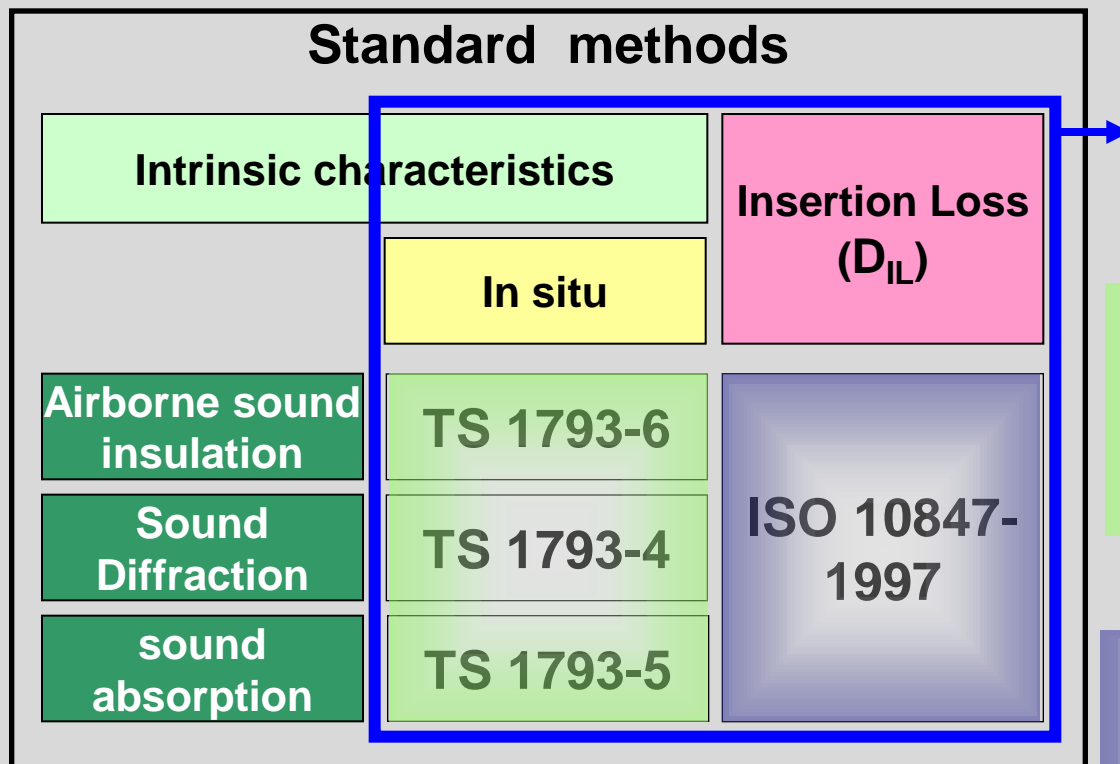

- TS 1793-4,5,6: to identify:
 - Poor materials quality
 - Faulty installation

+

- ISO 10847: to identify:
 - low project/design quality

CE marking >> DoP of the noise barrier system Structural performance (EN 1794-1)



Manufacturers shall declare maximum loads noise barrier are able to withstand provided maximum deflection of post and panels are not exceeded. Loads to be considered are wind load and variable loads due to passing vehicles



Structural calculation is currently performed on the supporting posts.

Laboratory tests are recommended for the noise panels

Noise barrier system - Structural performance

RAIL APPLICATION

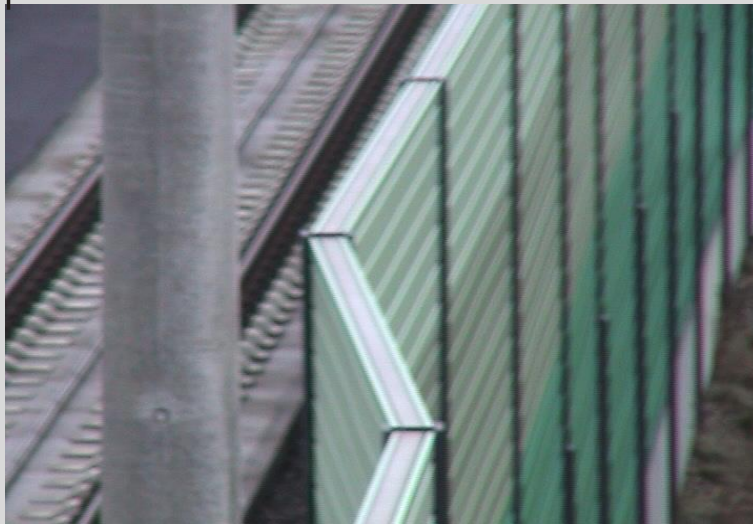
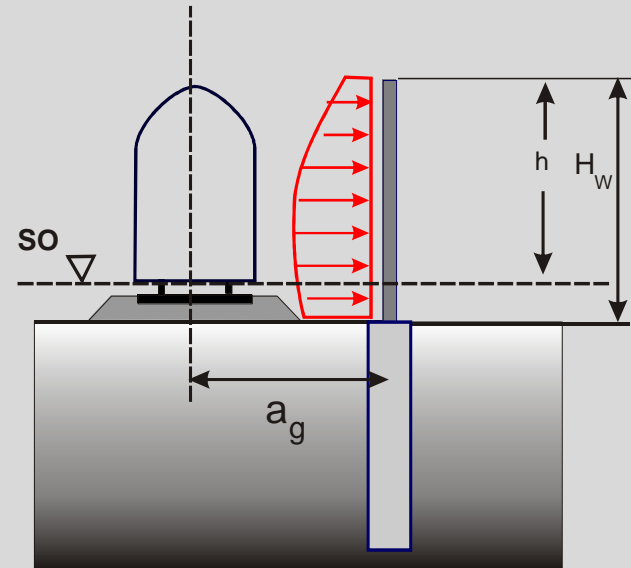
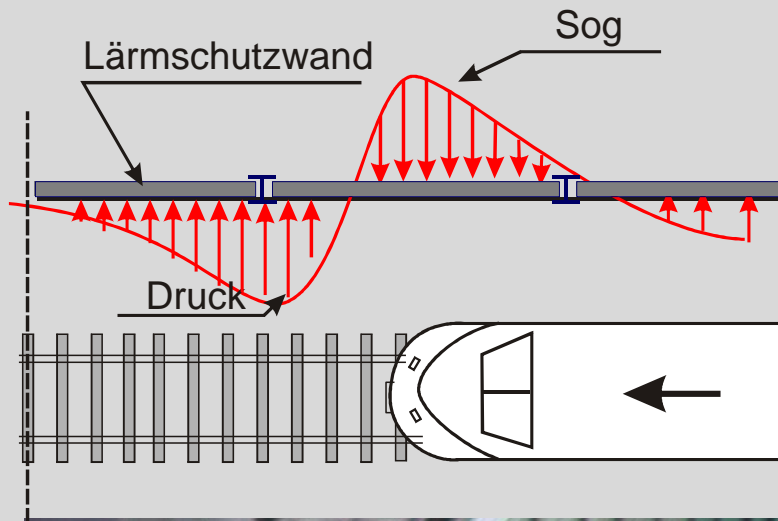

Alternating pressure and suction forces due to passing train main cause fatigue effect

CE marking >> DoP of the noise barrier system Structural performance: errant vehicles impact

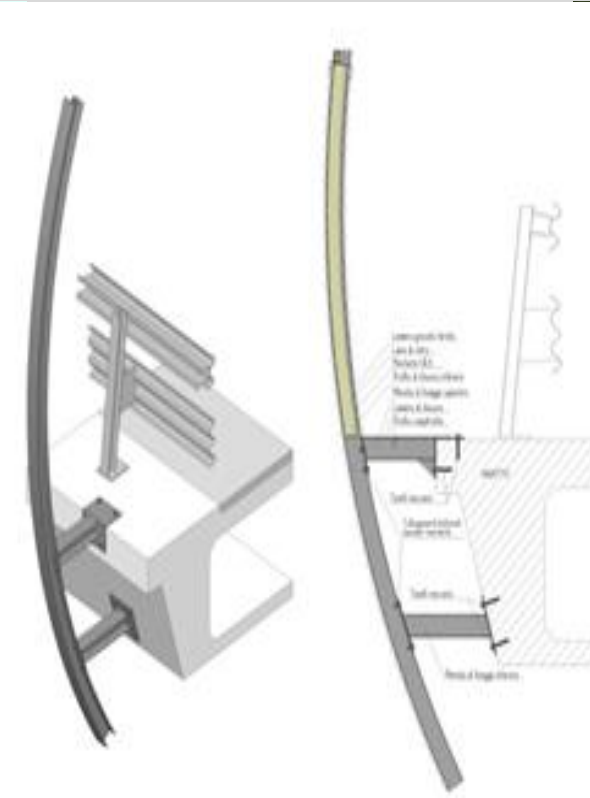

**Crash test to be performed according to EN 1317
in case of integrated noise and safety barrier**

DoP of the noise barrier system

Structural performance: risk from falling debris

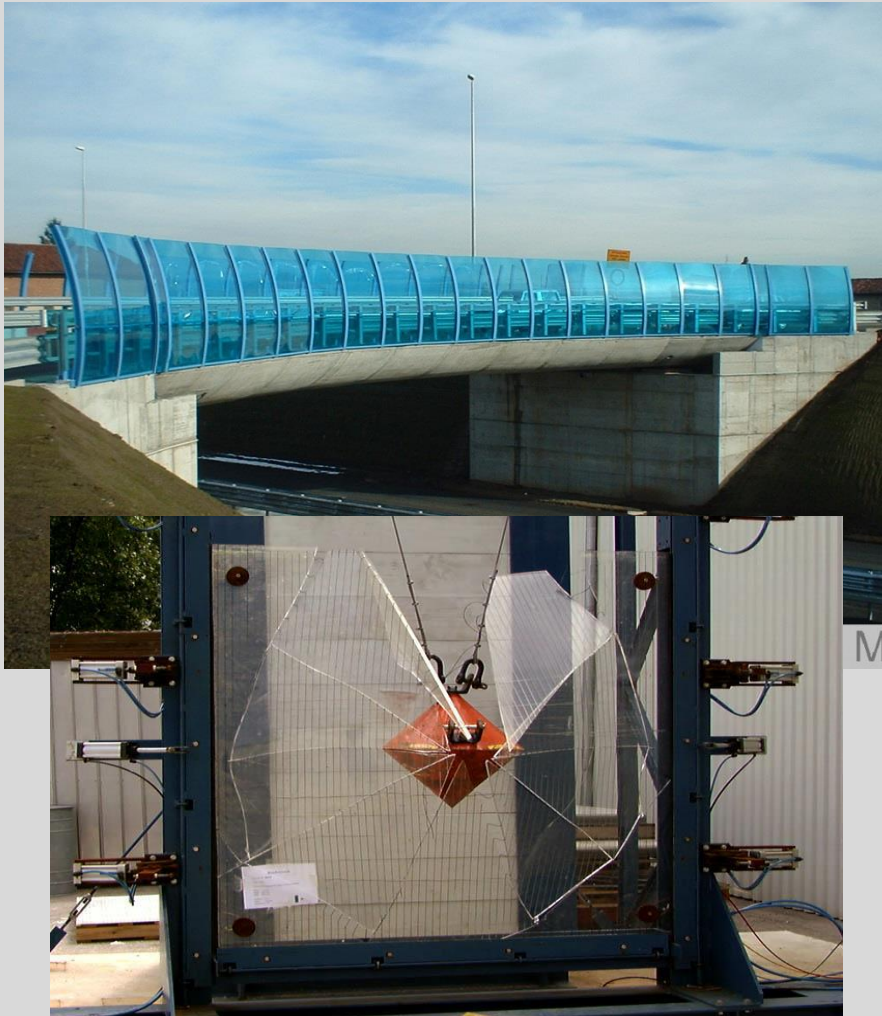

Risk from falling debris may occur in case of noise barrier installed on bridges or critical positions – (EN 1794-2)

Use of intrinsic resistant materials is essential as the evaluation of performance is to be made on the whole barrier (use of safety cables, secure posts etc)

DoP of the noise barrier system Safety in use : behaviour in case of fire

Noise barrier performance are currently evaluated by testing the system against brush fire EN 1794-3 Annex A.

Classification of products according to Euroclasses (EN 13501) is recommended for some intended use as per attach table:

Table B.1 — Classification of reaction to fire for noise reducing devices (informative)

Class	Intended use	Test performances
1	Tunnels and total covers	Class B or better according to EN 13501
2	Partial covers, on bridges and near houses	Class E or better according to EN 13501
3	All other situations where fire could be relevant	Test results according to Annex A

DoP of the noise barrier system Long term durability EN 14389.1,2

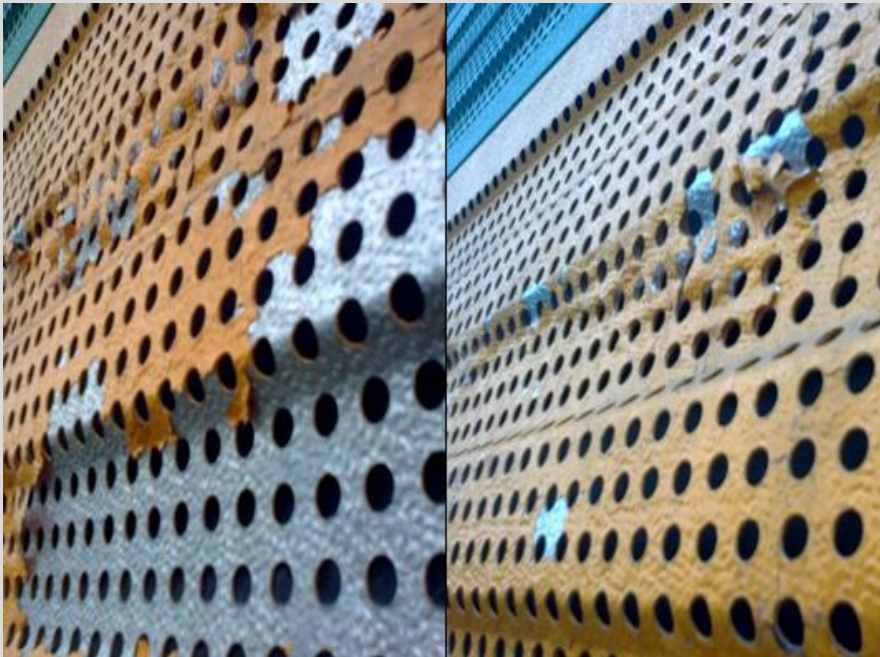

Material specification (corrosion protective layers, wood treatment) are essential for long term durability. Also to be considered assembling system, water drainage..

Toward a protocol for Sustainability Assessment



Noise barriers are almost always paid by public funding.



Are there possible income funds to cover costs ?

Thanks for your attention

for futher info pls see

www.enbf.org